



SEATED PALLET STACKER L14 RW | L16 RW

CAPACITY 1400 - 1600 KG | SERIES 1174

Safety

High performance combined with safety. The Linde Load Management system automatically calculates residual capacity. It warns the operator and deactivates the lift function when approaching load capacity limits. The efficient braking systems and the four point configuration ensures inherent stability. The operator is always safely within the chassis contour and is also protected by the overhead guard.

Performance

High operational efficiency is this truck's true strength. The 3 kW AC motor enables speeds up to 12km/h. The robust chassis structure provides exceptional residual capacities with nominal capacities from 1400 kg up to 1600 kg and a lifting height of up to 6.2m.

Comfort

The 90° sitting position provides excellent all-round visibility over the environment. The spacious operator's compartment and the padded armrest offer a stress-free working environment for optimum efficiency and productivity. All the operating controls incorporated in the console

are easily accessible. The sitting position and the floorplate are adjustable to suit every operator's preferences.

Reliability

Rugged construction and the use of tried and tested components ensure this a truck that can be relied on. Motor, sub-components and electronics are all protected within the robust chassis structure. With the initial lift version (option), the ground clearance is improved to cope with gradients and uneven floors. These features guarantee a longer operating life, delivering safe, efficient, and productive load handling.

Service

Efficiency at work and efficiency in servicing with cost effective maintenance routines. Easy access to all components and maintenance-free technology also play their part in increasing truck up-time and availability. CAN bus connectivity provides a computerized diagnostic system for rapid analysis to ensure maintenance intervals are also minimized.

TECHNICAL DATA

ACCORDING TO VDI 2198

				LINDE	LINDE
				L14 RW	L16 RW
Characteristics	1.1	Manufacturer		LINDE	LINDE
	1.2	Model design		L14 RW	L16 RW
	1.3	Power unit		Battery	Battery
	1.4	Operation		Seat	Seat
	1.5	Load capacity / Load	Q (t)	1.4	1.6
	1.6	Load centre distance	c (mm)	600	600
	1.8	Axle centre to fork face	x (mm)	724 (645)	724 (645)
	1.9	Wheelbase	y (mm)	1603	1603
	Weight	2.1	Service weight	(kg)	1616 (1697)
2.2		Axle load with load, front / rear	(kg)	1174 / 1842 (1227 / 1870)	1190 / 2026 (1243 / 2054)
2.3		Axle load without load, front / rear	(kg)	1066 / 550 (1119 / 578)	1066 / 550 (1119 / 578)
Wheels and types	3.1	Tyres rubber, SE, pneumatic, polyurethane		V + P / P	V + P / P
	3.2	Tyre size, front		Ø 254 x 102	Ø 254 x 102
	3.3	Tyre size, rear		Ø 85 x 60	Ø 85 x 60
	3.4	Auxiliary wheels (dimensions)		Ø 140 x 50	Ø 140 x 50
	3.5	Wheels, number front/rear (x = driven)		1x + 1/4	1x + 1/4
	3.6	Track width, front	b ₁₀ (mm)	699	699
	3.7	Track width, rear	b ₁₁ (mm)	380	380
Dimensions	4.2	Height of mast, lowered	h ₁ (mm)	2365	2365
	4.3	Free lift	h ₂ (mm)	150	150
	4.4	Lift	h ₃ (mm)	3744	3744
	4.5	Height of mast, extended	h ₄ (mm)	4264	2260
	4.6	Initial lift	h ₅ (mm)	(-125)	(-125)
	4.7	Height of overhead guard (cabin)	h ₆ (mm)	2260	2260
	4.8	Height of seat/stand on platform	h ₇ (mm)	1166	1166
	4.10	Height of reach legs	h ₈ (mm)	80	80
	4.15	Height, lowered	h ₁₃ (mm)	86	86
	4.19	Overall length	l ₁ (mm)	2187	2187
	4.20	Length to fork face	l ₂ (mm)	1037	1037
	4.21	Overall width	b ₁ / b ₂ (mm)	970	970
	4.22	Fork dimensions DIN ISO 2331	s / e / l (mm)	71 x 180 x 1150	71 x 180 x 1150
	4.24	Width of fork carriage	b ₃ (mm)	780	780
	4.25	Fork spread	b ₅ (mm)	560	560
	4.32	Ground clearance, centre of wheelbase	m ₂ (mm)	30 (20)	30 (20)
	4.33	Load dimension b ₁₂ x l ₆	b ₁₂ x l ₆ (mm)	800 x 1200	800 x 1200
4.34	Aisle width predetermined load dimensions	A ₃₁ (mm)	2618	2618	
4.35	Turning radius	W ₉ (mm)	1796	1796	
Performance	5.1	Travel speed, with / without load	(km/h)	10 / 12	10 / 12
	5.2	Lifting speed, with / without load	(m/s)	0.144 / 0.447 (0.045 / 0.088)	0.144 / 0.447 (0.045 / 0.088)
	5.3	Lowering speed, with / without load	(m/s)	0.343 / 0.342 (0.076 / 0.072)	0.343 / 0.342 (0.076 / 0.072)
	5.8	Maximum climbing ability, with / without load	(%)	13.0 / 20.0 (12.0 / 20.0)	13.0 / 20.0 (12.0 / 20.0)
	5.9	Acceleration time, with / without load	(s)	5.6 / 4.7	5.6 / 4.7
	5.10	Service brake		Electro-magnetic	Electro-magnetic
Drive Unit	6.1	Drive motor rating S2 60 min	(kW)	3	3
	6.2	Lift motor rating at S3 15 %	(kW)	3.2	3.2
	6.3	Battery according to DIN 43531 / 35 / 36 A, B, C, no		no	no
	6.4	Battery voltage / rated capacity (5h)	(V) / (Ah)	24 / 345 / 375	24 / 345 / 375
	6.5	Battery weight (± 5 %)	(kg)	288	288
	6.6	Power consumption according to VDI cycle	(kWh/h)	1.41	1.41
	6.7	Turnover output	(t/h)	67.2	67.2
	6.8	Energy consumption at turnover output	(kWh/h)	2.08	2.08
8.1	Type of drive unit		LAC	LAC	
10.7	Sound pressure level LpAZ (at the driver's seat)	(dB(A))	65	65	

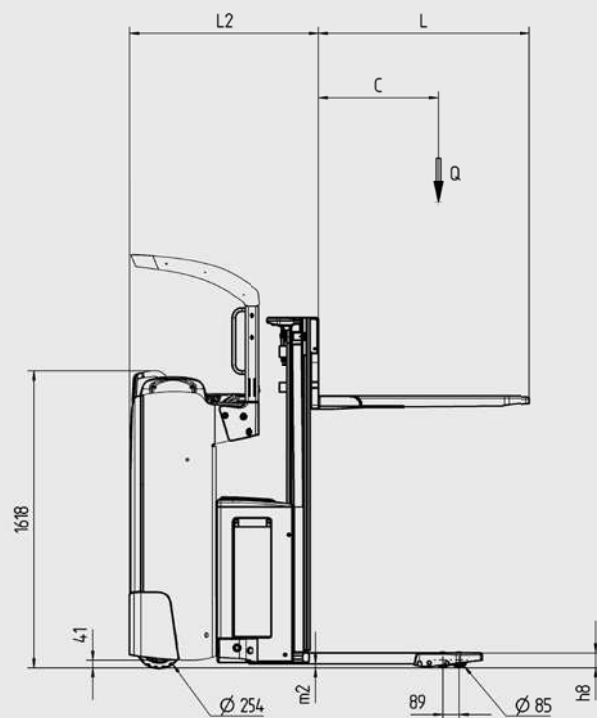
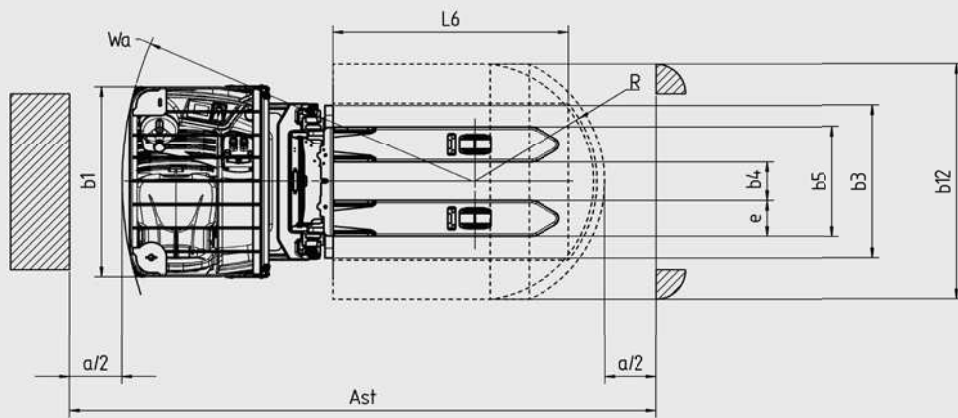
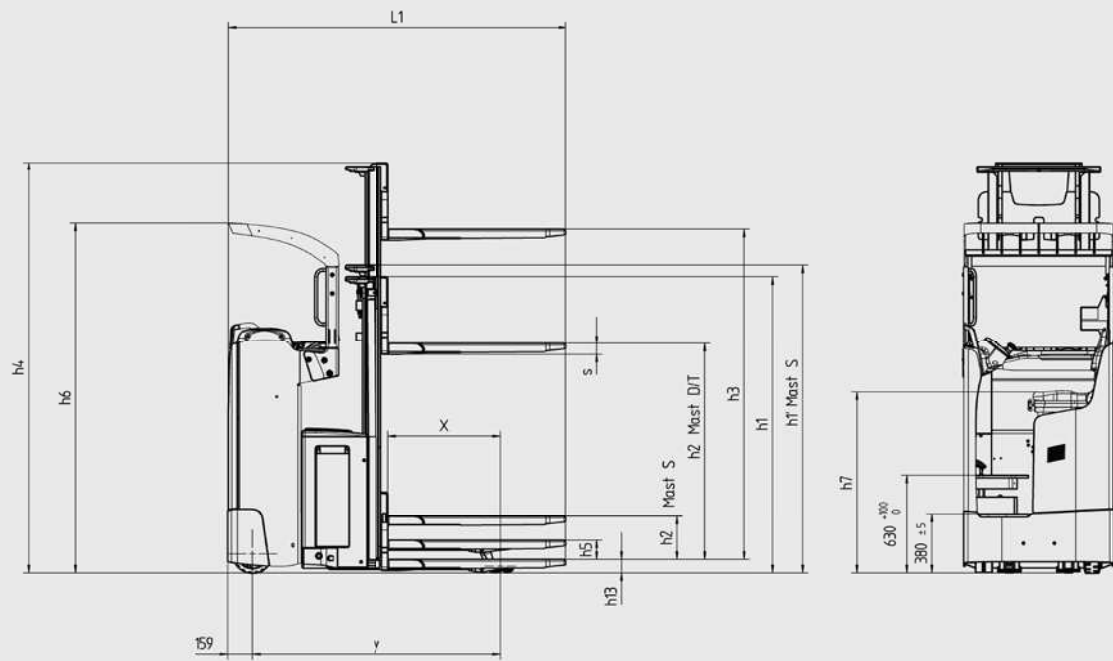

STANDARD EQUIPMENT / OPTIONAL EQUIPMENT

STANDARD EQUIPMENT

Chassis width 970 mm
Key switch or PIN Code access
Multifunction coloured display hour meter, maintenance indication, battery discharge indicator and internal fault code indication
Power assisted steering
Automatic speed reduction when cornering
ECO-Mode with up to 12% energy savings
3 kW AC motor (maintenance free)
Drive wheel position mentioned in display
Lateral battery change 3 PzS available with ergonomic battery un/locking with lever and rollers ($l_2=1037$ mm)
CAN bus technology
Overhead guard
Soft landing on forks
Floor compensator
Drive wheel Polyurethane
Tandem load wheel Polyurethane
Chassis for load arm width 560 and 680 mm
Protection -10°C

OPTIONAL EQUIPMENT

Initial lift ($h_5=125$ mm)
Ultra fast lifting (up to +40%)
Drive wheels: cushion rubber, synthetic cushion rubber non marking, wet grip
Load wheels: tandem polyurethane greasable
Lateral battery change 3 PzS/4 PzS available with an ergonomic battery un/locking with lever and rollers ($l_2=1112$ mm)
Leather seat and seat heating
Head support
Various Standard, Duplex and Triplex masts (up to 6200 mm lift height)
Mast Protection: polycarbonate, steel mesh
Speed reduction if forks lowered
Alternative fork carriage length/thickness: 950 mm or 1150 mm /71 mm or 55 mm (preferred while using gitter box)
Blue Spot
Flashing beacon
Support Clipboard DIN A4 and panoramic mirror
Support data terminal incl. power supply cable 24V
Mobile or Fixed battery stand
Cold store protection -35°C
Other options available on request

Linde Connected Solutions:

ac: access control (PIN or RFID Dual),
an: usage analysis and dt: crash detection

Data transfer Online

Data transfer WIFI

Bluetooth USB Stick

Li-ION technology:

4 PzSL compartment: 4.5 kWh - 9 kWh (205 Ah - 410 Ah)

Li-ION charger:

24V-Charger v25S: 4.5 kWh (full charging time 1h30min) - 9.0 kWh (2h40min)

MAST TABLES

Mast 1.4 and 1.6 t (in mm)		1844 S	2344 S	2844 S	3244 S	3744 S	4144 S	4644 S	1844 D	2344 D
Height, mast lowered	h_1	1415	1665	1915	2115	2365	2565	2815	1415	1665
Closed height (with free lift at 150 mm)	h_v	1490	1740	1990	2190	2440	2640	2890	/	/
Free lift	h_2	150	150	150	150	150	150	150	895	1145
Lift	h_3	1844	2344	2844	3244	3744	4144	4644	1844	2344
Height, mast extended	h_4	2364	2864	3364	3764	4264	4664	5164	2364	2864

Mast 1.4 and 1.6 t (in mm)		2844 D	3244 D	3744 D	4266 T	4716 T	5466T	6216T
Height, mast lowered	h_1	1915	2115	2365	1915	2065	2315	2565
Closed height (with free lift at 150 mm)	h_v	/	/	/	/	/	/	/
Free lift	h_2	1395	1595	1845	1395	1545	1795	2045
Lift	h_3	2844	3244	3744	4266	4716	5466	6216
Height, mast extended	h_4	3364	3764	4264	4786	5236	5986	6736
Other masts on request. S = Standard, D = Duplex, T = Triplex								



FEATURES

Lifting systems

- Precise, effortless fingertip control of all mast movements
- Soft landing on forks protects the load when lowering
- Initial lift independent of main lift
- Max. lift height up to 6200 mm
- Max. load capacity in Stacker use: 1600 kg on load arms



Linde Load Management

- Immediate calculation of the current weight and lifting height
- Calculates in live if the operator is approaching or over the residual capacity limit
- Informs on potential maximum height and weight
- Information available at a glance on a wide multifunctional display
- Acoustic and visual warning with blinking red light.

Handling

- Chassis width $b_1 = 970$ mm
- Initial lift = 125 mm
- High seated position for excellent visibility
- Stable 4 point configuration
- Pallet stop for fast, efficient stacking of two pallets

Comprehensive energy solutions

- 24V batteries: capacities from 345 Ah (3PzS) to 500 Ah (4PzS)
- 24V high batteries: capacities from 420 Ah (3PzS) to 620 Ah (4PzS)
- Li-ION batteries with 4.5 kWh (205 Ah) and 9.0 kWh (410 Ah)

Drive control and settings

- Compact steering wheel integrated into the console
- Traction speed automatically reduces in relation to the steering angle
- ECO-Mode up to 12% energy savings to finish shift with low battery status



Workstation

- Multifunctional instrument display with easy ergonomic menu
- Truck access control by PIN code or ignition key
- Storage compartment for work gloves, writing utensils etc.
- Emergency isolator

Ergonomics and sitting position

- 90° Side-stance seating posture ensures excellent visibility
- Padded armrest and easy access to all operating controls
- Three independent adjustments systems: backrest adjustable, length adjustable, weight adjustable for operator's comfort
- Adjustable floor plate

Twin or single pedal

- Seamless and effortless forward/reverse selection provides outstanding traction control and places minimal demands on operator
- The left foot is safely protected within the chassis contours
- The operator is able to maintain high levels of efficiency and productivity

Subject to modification in the interest of progress. Illustrations and technical details could include options and not binding for actual constructions. All dimensions subject to usual tolerances.



FARO

CARRELLI ELEVATORI